

## 3 Channel Constant Voltage Power Repeater

Model No.: EV3-X

3 Channel/PWM signal input/Constant voltage output/3KV optoelectronic isolation



CE RoHS LVD

### Features

- 12-36V constant voltage power repeater.
- 3 channel, 10A per channel.
- To receive PWM signal control.
- Power repeater in series or in parallel to expand output unlimitedly.
- Apply to single color or RGB constant voltage LED strip or module.

### Technical Parameters

Input and Output	
Input voltage	12-36VDC
Input current	30.5A
Input signal	PWM
Output voltage	3 x [12-36]VDC
Output current	3CH, 10A/CH
Output power	3 x [120-360]W
Output type	Constant voltage
Environment	
Operation temperature	Ta: -30°C ~ +55°C
Case temperature (Max.)	Tc: +85°C
IP rating	IP20

Safety and EMC		
EMC standard (EMC)	EN301 489, EN 62479	
Safety standard(LVD)	EN60950	
Certification	CE, EMC, LVD	

Warranty and Protection	
Warranty	5 years
Protection	Reverse Polarity

Weight	
Net weight	0.256kg
Gross weight	0.270kg

### Mechanical Structures and Installations

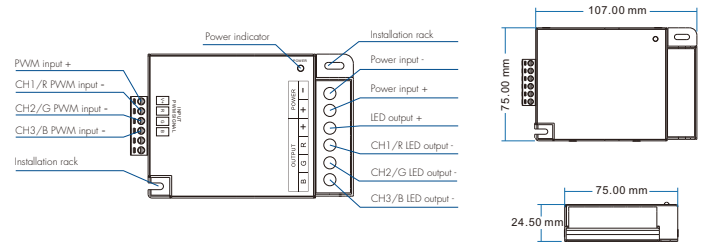

### Wiring Diagram

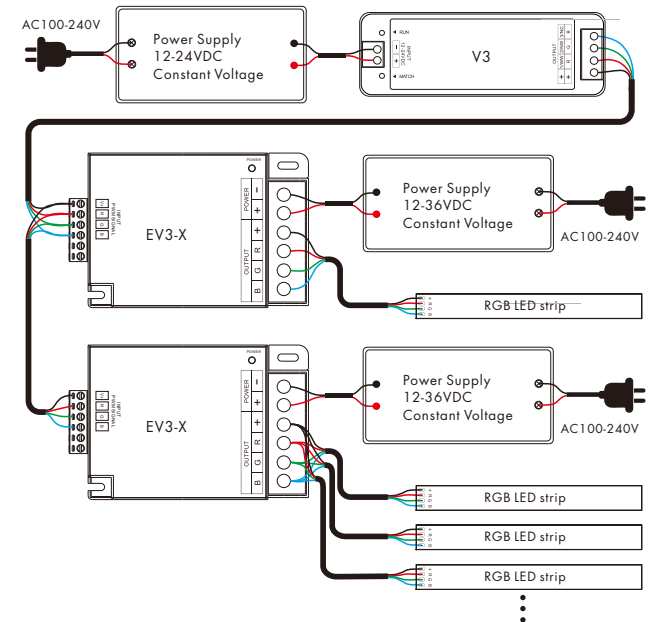

## Malfunctions analysis & troubleshooting

Malfunctions	Causes	Troubleshooting
No light	1. No power. 2. Wrong connection or insecure.	1. Check the power. 2. Check the connection.
Wrong color	1. Wrong connection of R/G/B wires.	1. Reconnect R/G/B wires.
Uneven intensity between front and rear, with voltage drop	1. Output cable is too long. 2. Wire diameter is too small. 3. Overload beyond power supply capability. 4. Overload beyond controller capability.	1. Reduce cable or loop supply. 2. Change wider wire. 3. Replace higher power supply. 4. Add power repeater.

## Safety & Warnings

1. The product shall be installed and serviced by a qualified person.
2. This product is non-waterproof. Please avoid the sun and rain.
3. Good heat dissipation will prolong the working life of the controller, Please ensure good ventilation.
4. Please check if the output voltage of any power supplies used comply with the working voltage of the product.
5. Ensure all wire connections and polarities are correct and secure before applying power to avoid any damages to the LED lights.
6. If a fault occurs please return the product to your supplier. Do not attempt to fix this product by yourself.